



PENTAIR

Centrifugal Pumps For Maritime Applications

PRESENTER NAME HERE

Date goes here

Maritime Applications



- Dredgers
- Heavy lift vessels
- FPSO's (Oil & Gas)
- Cargo vessels
- Tug boats / Supply vessels
- Offshore platforms
- Cruise liners

More than 100 years of experience

Maritime Applications

PENTAIR'S STRENGTHS IN MARITIME APPLICATIONS

- Cooling water Pumps for propulsion systems
- Pumps for auxiliary systems
- Pumps for special ships applications

Heavy lift vessel Mighty Servant 3





PRODUCT OVERVIEW

Maritime Applications



vertical turbine pump



end suction pump



mixed flow pump



self priming pump

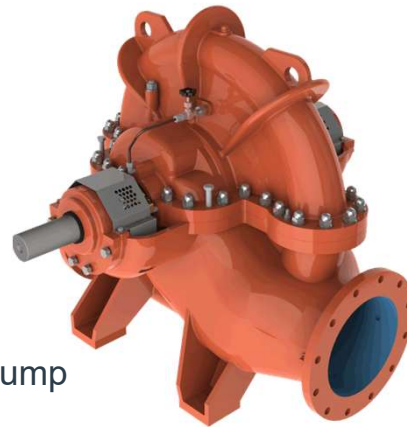

split case pump

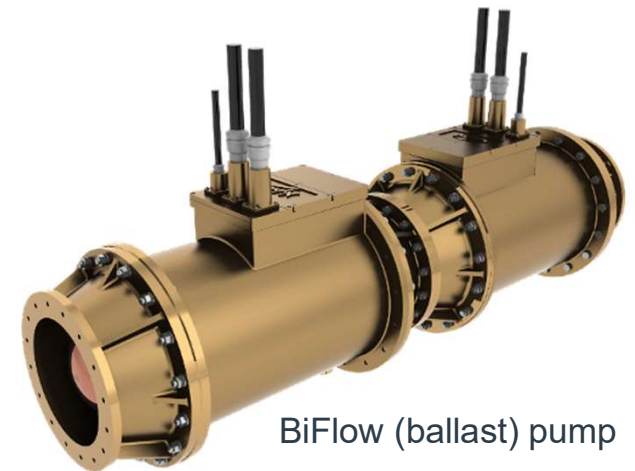

BiFlow (ballast) pump

• Capacity from 10 – 16.000 m³/h +

• Heads from 1 – 250 mlc



DREDGING INDUSTRY

Dredging Industry



LAND RECLAMATION PROJECTS

- TSHD and CSD are equipped with Pentair Fairbanks Nijhuis pumps



Dredging industry

MAIN PUMP APPLICATIONS



Glandpumps



Jetpump set

“WEAR RESISTANT” IS THE KEY WORD FOR PUMPS IN DREDGING

Dredging Industry

JETPUMPS

Common configuration

- Shaft sealing: Liquidyne seals
- Casing and impeller of Alluminiumbronze
- Casing of Duct. Cast-iron GGG50 with internal coating

Special configuration (larger types):

- Extra studs in upper casing
- Hooked wearings pumps

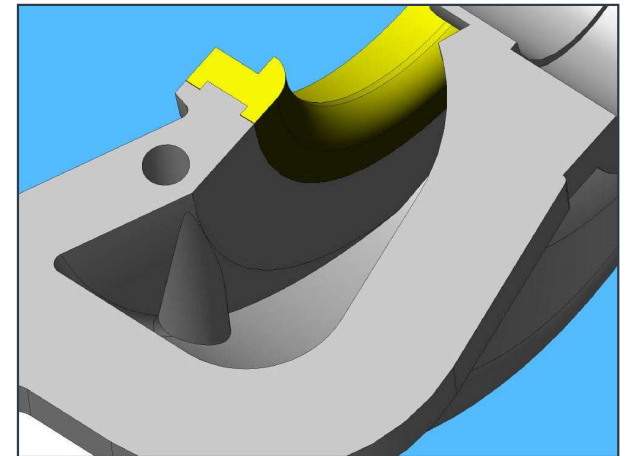
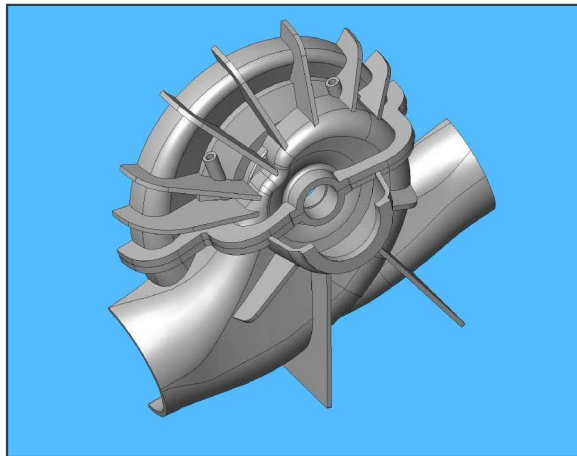

Dredging Industry

GLANDPUMPS (VARIABLE SPEED / HIGH PRESSURE)

Common configuration

- Shaft sealing: Liquidyne seals
- Casing and impeller of Aluminiumbronze

Special configuration (larger types)

- Enlarged pedestal
- Hooked wearings
- Ceramic nose bearing

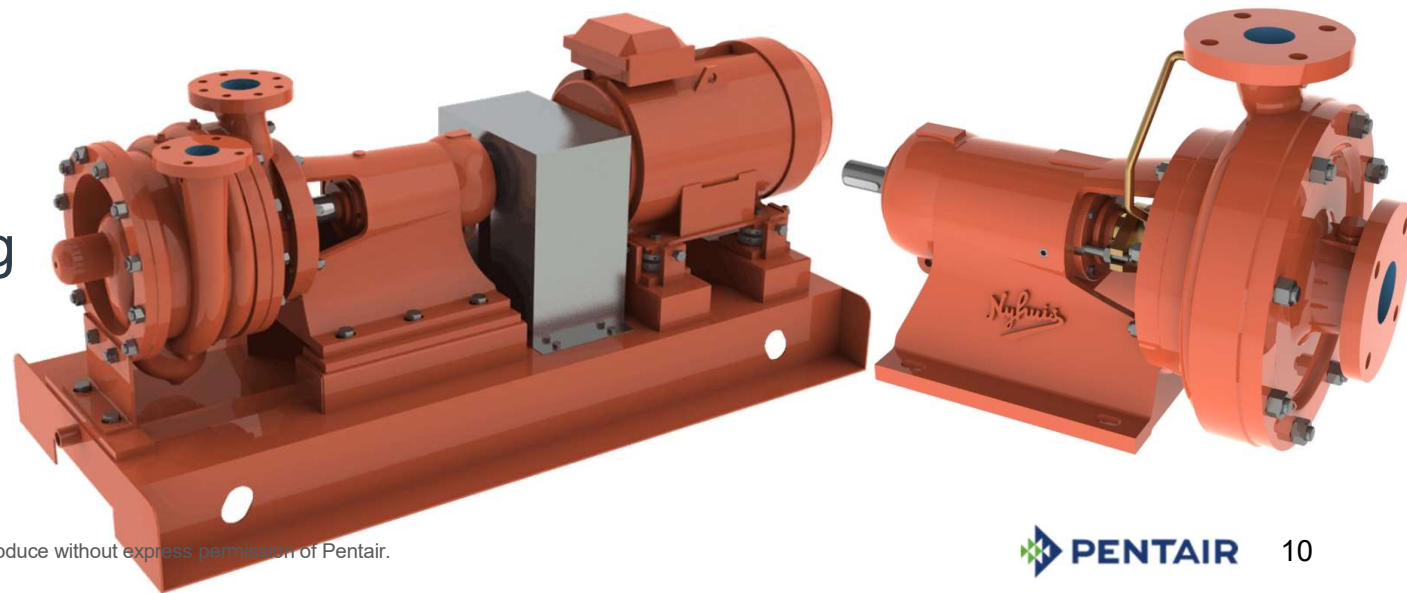
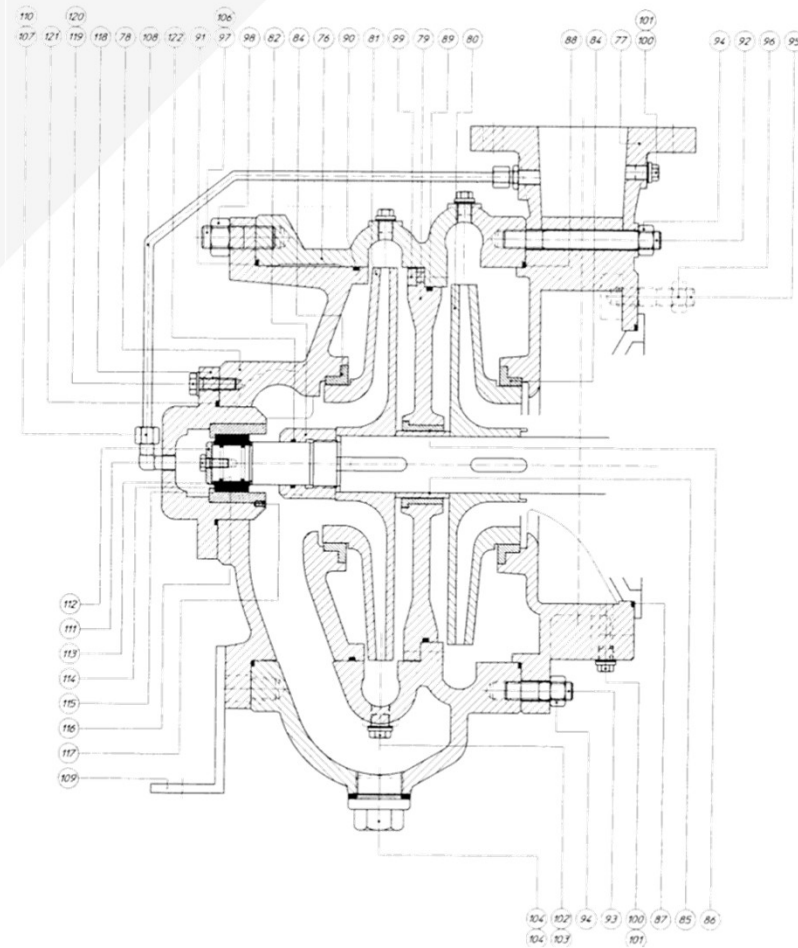

Dredging Industry



HOPPER FLUSHING PUMP

- Transport of large amounts of water
- Enlarging lifetime of Jetpump
- High efficiency pump

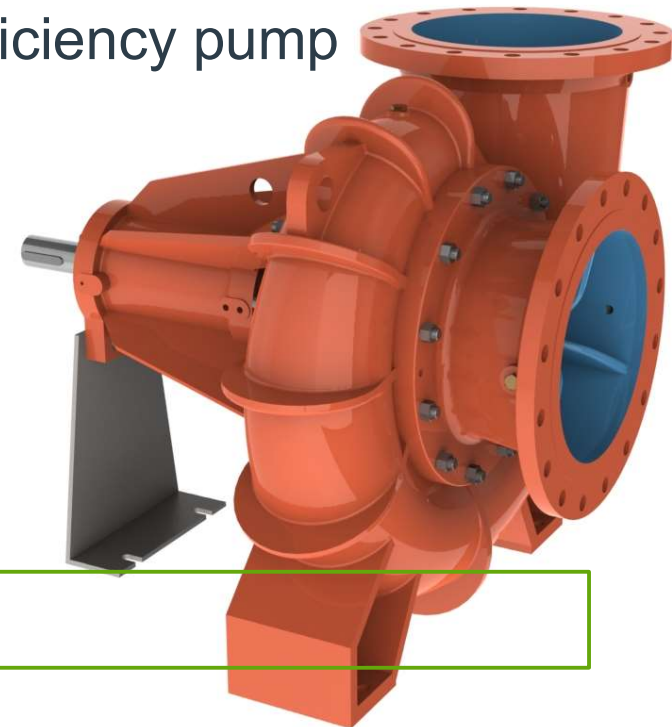



OR OTHER VESSELS WITH LARGE BALLAST WATER SYSTEMS

HEAVY LIFT VESSELS

Heavy Lift Vessels

- Transport of large amounts of ballast water
- Capacities up to 3000m³/hour
- Bi-directional / in-line ballast pump
- Submerged if required
- Minimum of space and piping

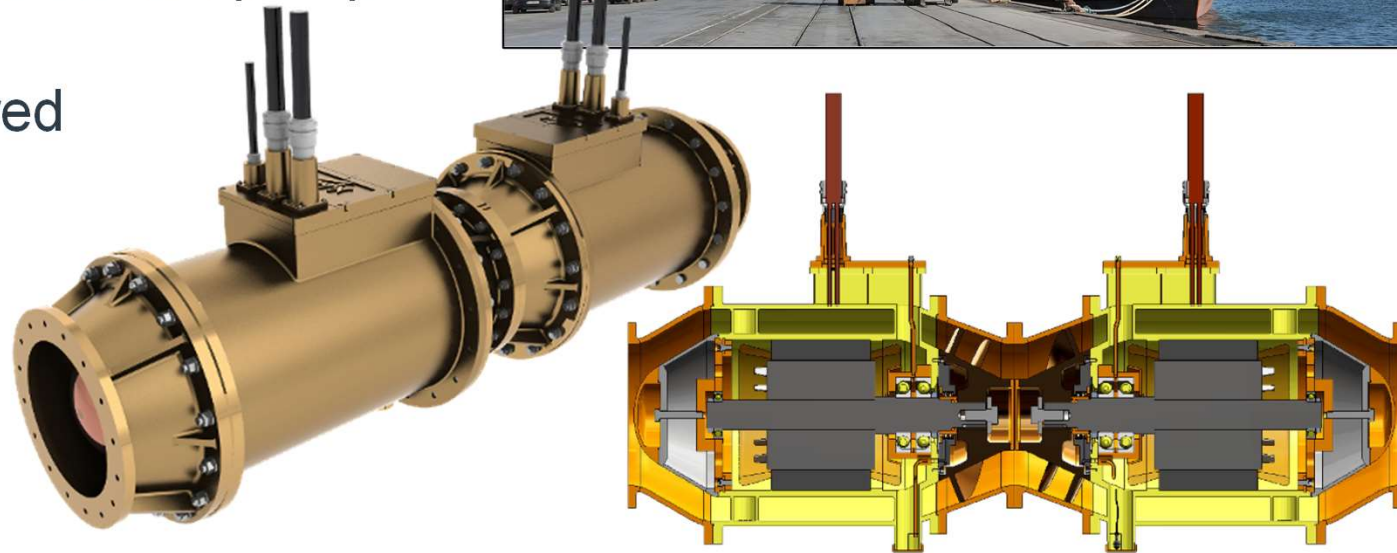

THE FAIRBANKS NIJHUIS' BIFLOW PUMP IS THE SOLUTION TO REDUCE EXPENSIVE TIME IN PORT



OIL & GAS – FPSO'S

Oil & GAS – FPSO's

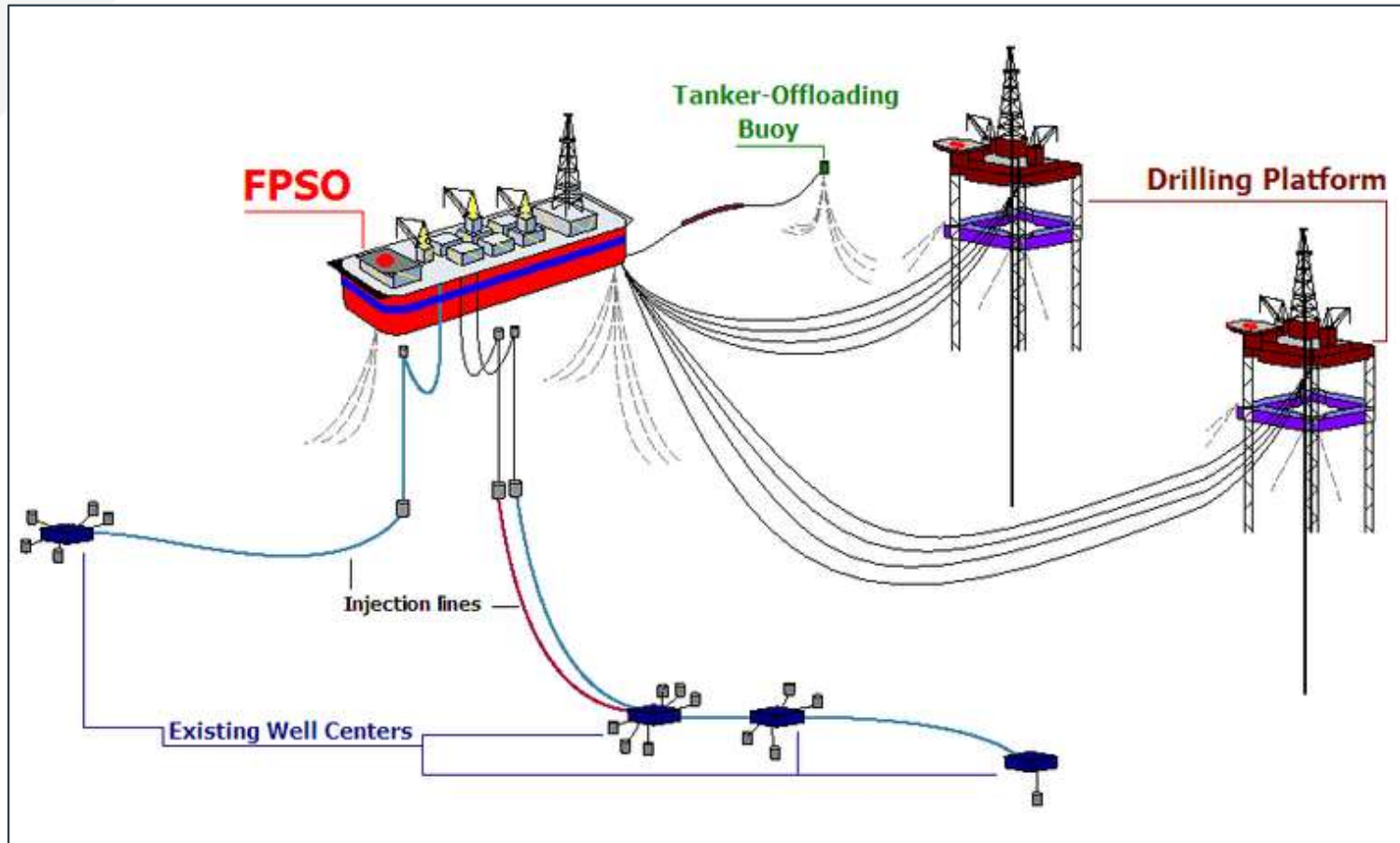

RELIABILITY” IS THE KEY WORD FOR PUMPS ON FPSO’S

Oil & Gas – FPSO'S

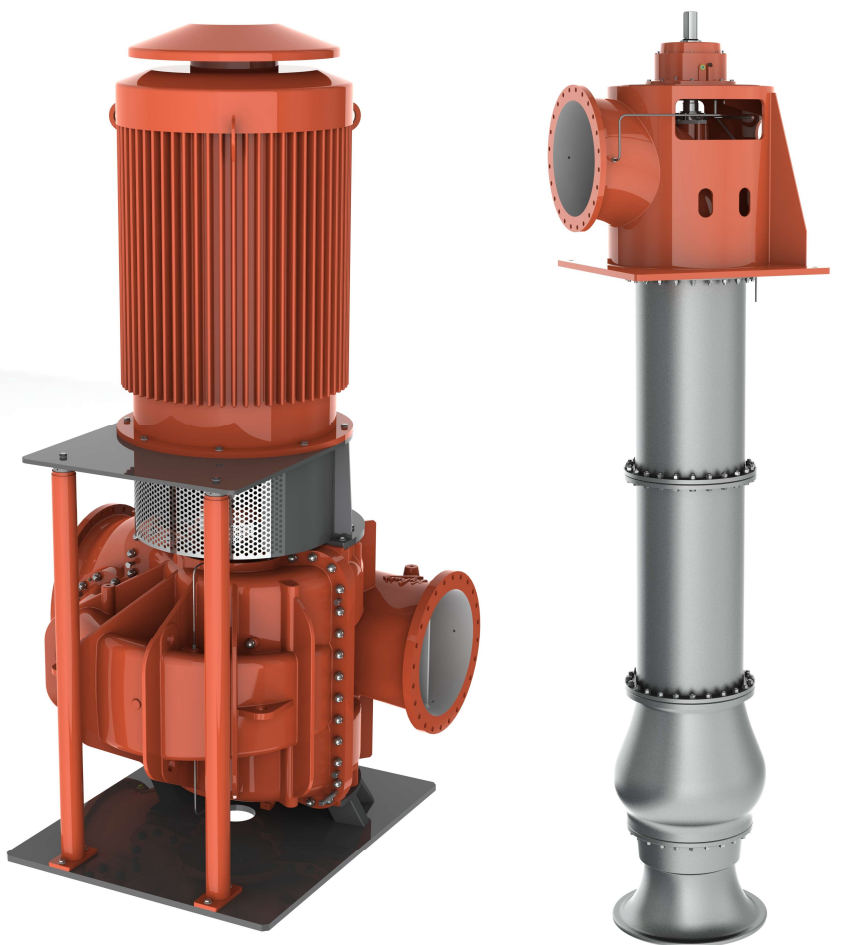

SEAWATER LIFT PUMPS

Common configuration

- Vertical split case / Vertical turbine
- Sea water resistant material; e.g. Aluminium bronze / Duplex SS
- Heavy duty marine configuration

Special configuration:

- Hazardous area (Ex motors)
- E-motors on different deck



MARITIME FIRE FIGHTING

Maritime Fire Fighting

OFFSHORE PUMP SETS

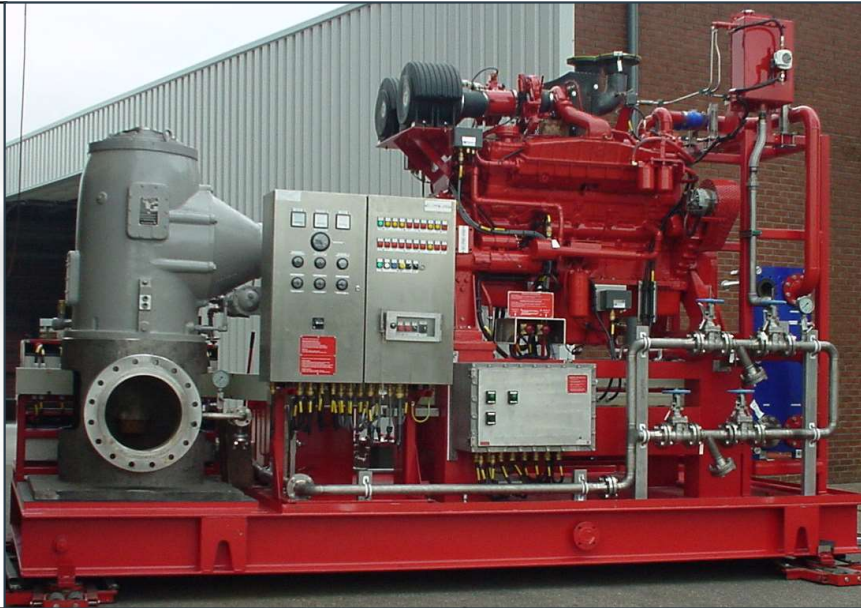
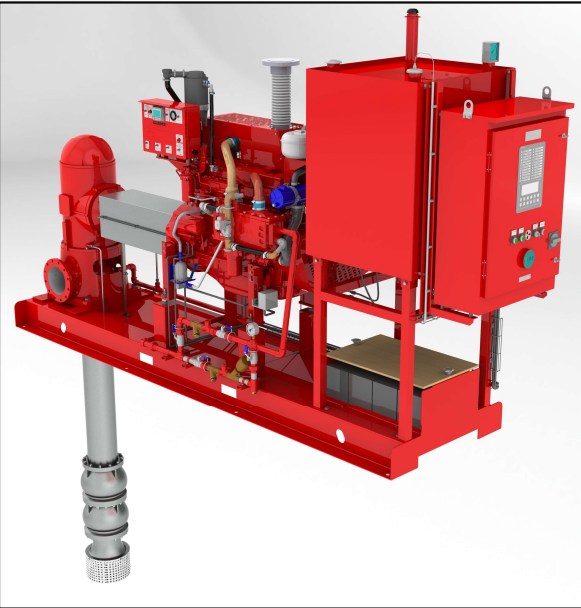

Maritime Fire Fighting

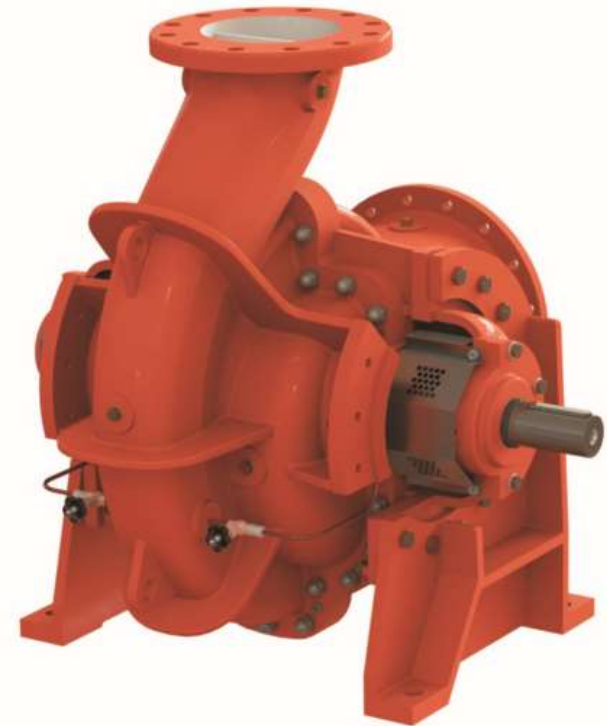

Fire fighting pumps according to FIFI class I, II and III



OR OTHER SHIPS WITH LARGE MAIN ENGINES

CONTAINER SHIPS

Container Ships (OR OTHER SHIPS WITH LARGE MAIN ENGINES)



LUBE OIL PUMPS WITH LARGE CAPACITY

- High efficiency
- Installed directly into the main engines' sump



MARITIME SERVICES

Maritime Services

- Training of end-users
- Worldwide technical support

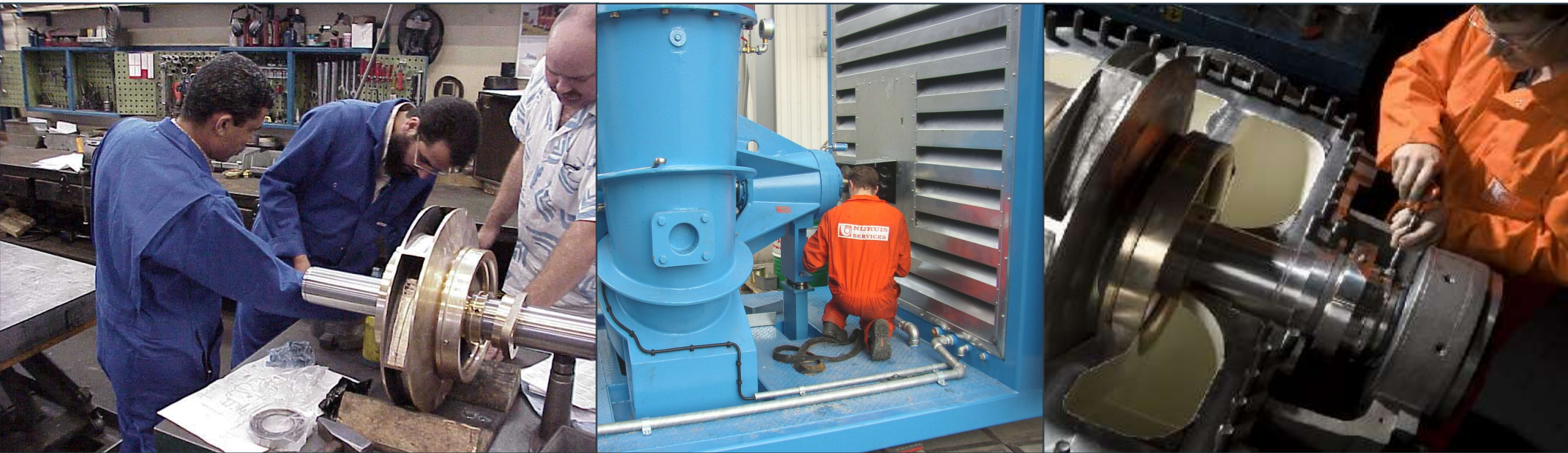

Maritime Services

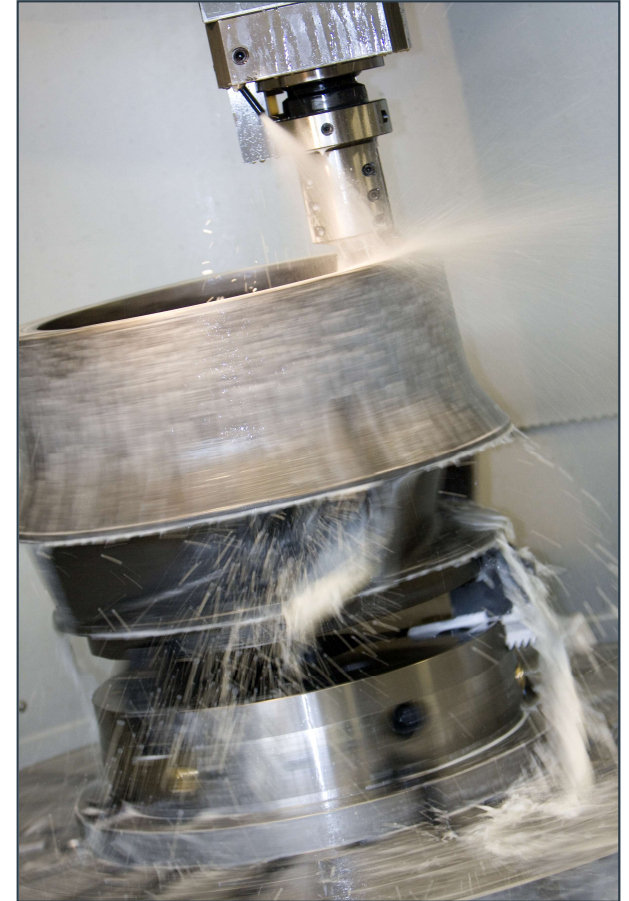

In-house Service foundry and machine shop for optimal spare parts delivery



THANK YOU

Parallelweg 4
7102 DE Winterswijk
The Netherlands

+31 543 547 474
Info.nijhuis@pentair.com
www.pentair.com